

MX2

EN



THERE IS NO SUBSTITUTE



GET CREATIVE - MX2 MAKES IT POSSIBLE



H₂O SMART™

INTELLIGENTLY SENSES H₂O AND AUTOMATICALLY ADJUST

- Perfect sous vide
- Liquids without spillage
- Faster cycle time

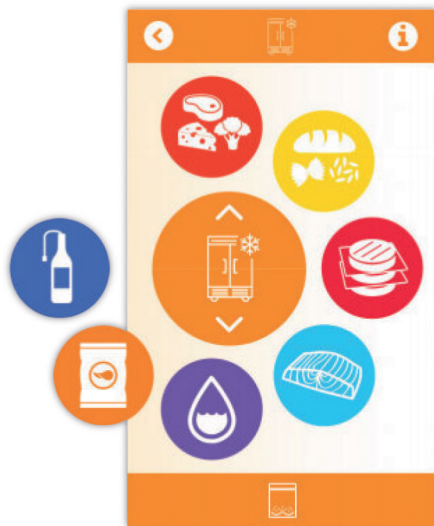

BEST IN ITS CLASS

- Extreme 7" (175 mm) deep
- Soft-close lid
- Auto alert oil cleaning

INTUITIVE ONE-TOUCH PRESET KEYS

- **Firm** Full vacuum for hardy foods
- **Soft** Lower vacuum with soft return
- **Formed** Super low air return
- **Fragile** Step and delay vacuum
- **Liquids** H₂O vacuum
- **Chips** Low vacuum with fast return
- **External** Wine and Containers



THIS IS NOT A VACUUM CHAMBER IT'S A HIGH-TECH KITCHEN TOOL UTILIZING VACUUM

PRESERVATION

- Reduce Product Loss
- Less Storage Space
- Increase Shelf Life
- Preserve Moisture
- No Odor Transfer
- Maintain Texture
- Sealed Package
- Enhance Flavor

PREPARATION

- Marination
- Sous Vide
- Compression
- Aeration
- Infusion
- Liquids



SPECIFICATIONS

STANDARD FEATURES

- Pop-Out Seal Bar Replacement
- Soft-Close Lid
- Extreme Chamber Depth 7" (175 mm)
- Auto Alert Oil Cleaning
- WiFi & Bluetooth Connectivity
- USB Port for Direct Thermal Label Printer
- TruVac™ Dual Sensors for Precise mbar
- H2O Smart™
- Angled Tray for Holding Liquid

ACCESSORIES

- Direct Thermal Label Printer (203 dpi)
- marination Container 1/4-Pan Depth 6" (150mm)
- K-Type Needle Temperature Probe
- Volume Plates

TECHNICAL

- Linux Embedded Operating System
- 5" LCD Touch Screen Display, Resistive Type
- 8GB microSD Storage
- Thermocouple Port

POWER

- 4.8 m3/h DVP Rotary Oil Pump
- 120V / 1-Ph / 3.3A / 60 Hz
- Optional: 220V / 1-Ph / 1.6A / 50-60 Hz

SHIPPING

- Shipping dimensions: 21"x16.5"x13"h
- Shipping weight: 55 lbs

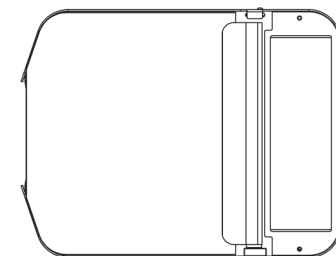
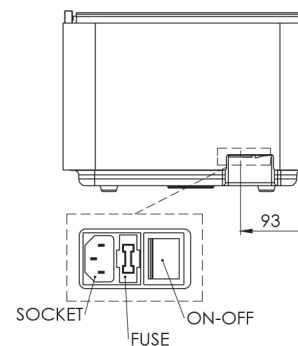
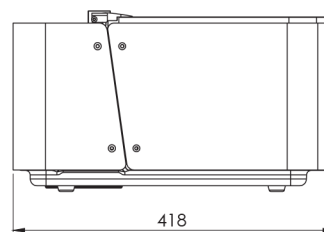
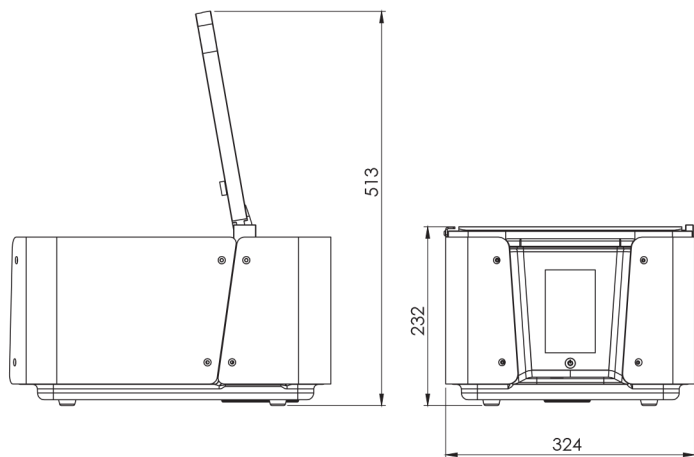
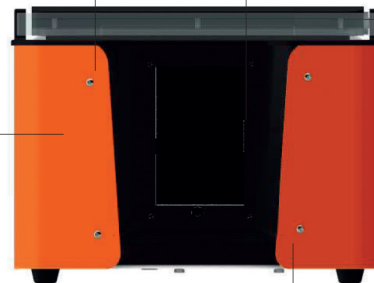



CHOOSE YOUR COLOR

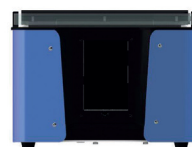

BIGGER MODELS COMING SOON...