

# Keisue

**Product Name:** LED Grow Light (IP66)

**Specification:** L1215 x W26.4 x H27mm

**Item No. :** KES-GL-002

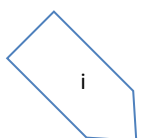

# Content

I.	Product.....	iii
	a) Product Definition.....	iii
II.	Product features.....	iii
III.	Product Properties.....	iv
	a) Product working circuit schematic diagram.....	iv
	b) Product basic working technical data (30CM distance measurement data) .....	iv
	c) Product illumination Graphic & testing data.....	iv
	d) Product photoelectrical testing data(Testing Distance:30CM).....	vi
V.	Product Main Material.....	vii
	d) LED Driver.....	vii
	e) LEDs.....	vii
	f) Heat Dissipation.....	vii
	g) Water-proof.....	vii
IV.	Product Size & Package.....	vii
	a) Product size illustration.....	vii
	b) Product packing illustration.....	viii
	c) Carton label.....	viii
V.	Product Installation Illustration.....	viii
VI.	QA & Safety Standard.....	x
	a) Quality control per ISO9001 -2008 Standard.....	x
	b) Quality Controlling Items.....	x
	c) Product Safety Certificates.....	xi
	d) Product Warranty Statement.....	xi
VII.	Product Usage Attention Items.....	xii

# I. Product

Product photo



## a) Product Definition

LED grow light belongs to new generation grow and assistant grow light for plants. The big difference compared with traditional grow light, whether it is HPS or fluorescent or other kinds, that is LED grow light can provide plants special requirement for different light wavelength and light intensity in their different grow phases to maximize the satisfaction for plant light necessity

# II. Product features

- . High power 3W 3535 LEDs
- . The lamp can be series connected and centralized turn on/off
- . Water-proof design, suitable for using in some special growing area

### III. Product Properties

#### a) Product working circuit schematic diagram

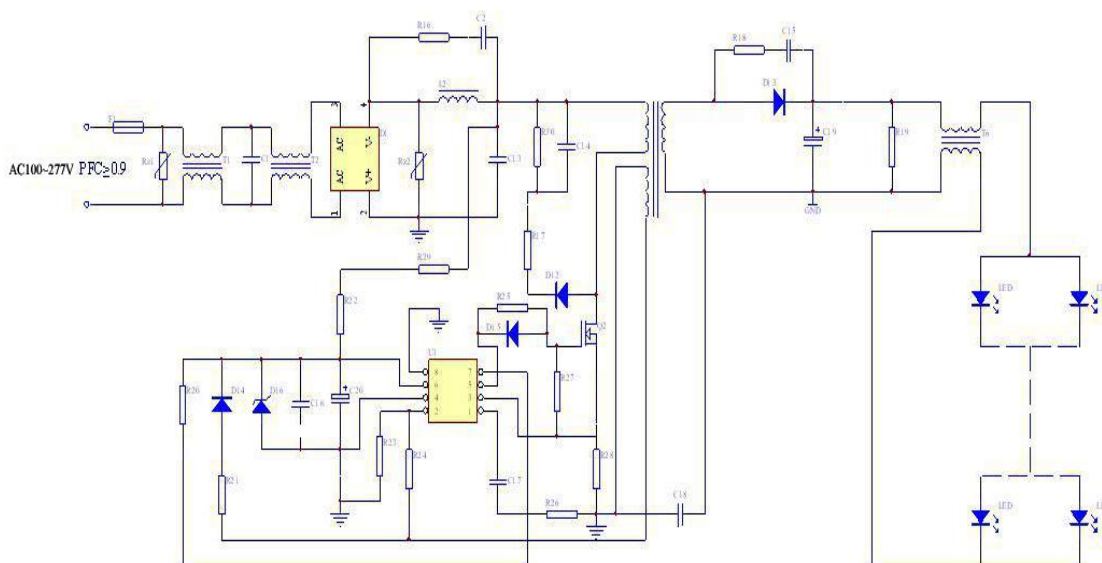

Attention: This diagram is for reference only, We have the right for the designing changes at any time in case we deem it necessary and will not be notified by our company!

#### b) Product basic working technical data (30CM distance measurement data)

Rated Power	Real power	Input Voltage	Working Frequency	LEDs
36W	26w	AC100~277V	50/60Hz	High Power 3W 3535 LEDs (We use 3W LEDs as 1W)
PF	Main Wave length	Ech-A(W/m <sup>2</sup> )	Ech-B(W/m <sup>2</sup> )	Color Ratio
≥0.9	380-780nm	11.438	7.3405	R/B/W: 4:1:1
Ee (W/m <sup>2</sup> )	PPFD (Eq)	Life-Span	Warranty	
(400-700nm) 26.803	133.29	50,000 H	3 years	

#### c) Product illumination Graphic & testing data

PPFD graph

Height

● 0		
● 0.1m	316.94	$\mu\text{mol}/(\text{m}^2 \cdot \text{s})$
● 0.2m	218.09	$\mu\text{mol}/(\text{m}^2 \cdot \text{s})$
● 0.3m	133.29	$\mu\text{mol}/(\text{m}^2 \cdot \text{s})$
● 0.4m	108.29	$\mu\text{mol}/(\text{m}^2 \cdot \text{s})$
● 0.5m	89.050	$\mu\text{mol}/(\text{m}^2 \cdot \text{s})$
● 0.6m	74.805	$\mu\text{mol}/(\text{m}^2 \cdot \text{s})$

**Illumination graph**

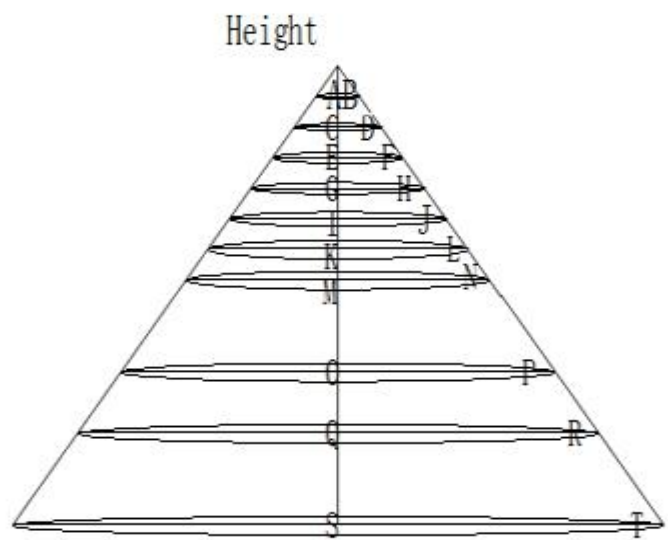

LED GROW LIGHT

0.1m	A	3799lx	B	219.4 lx
0.2m	C	2296lx	D	149.7 lx
0.3m	E	2238 lx	F	131.7 lx
0.4m	G	1572 lx	H	123.6 lx
0.5m	I	1475 lx	J	87.3 lx
0.6m	K	1261 lx	L	70.2 lx
0.7m	M	1042 lx	N	61.2 lx
1.0m	O	665.8 lx	P	28.6 lx
1.2m	Q	552.1 lx	R	30.9 lx
10.5m	S	396 lx	T	20.4 lx

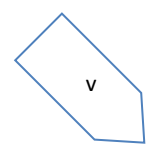

## c) Product photoelectrical testing data(Testing Distance:30CM)

Photoelectrical testing data by voltage setting 220V

### Spectrum Test Report

#### Sample Info.:

Name:Plant Growth Lamp	Type:GL
SN:KES-GL-002	Manu:KEISUE
Date:2018-08-09	Tester:CX YU
TMP:25.3 DEG	Humidity:65 %RH
Remark:4:1:1/Testing Distance 30CM	

#### Meter state:

Test Meter: PLA-20	Sensitivity: High	Average times: 1
Integral T: 74 ms	PeakAD Ip: 44525	

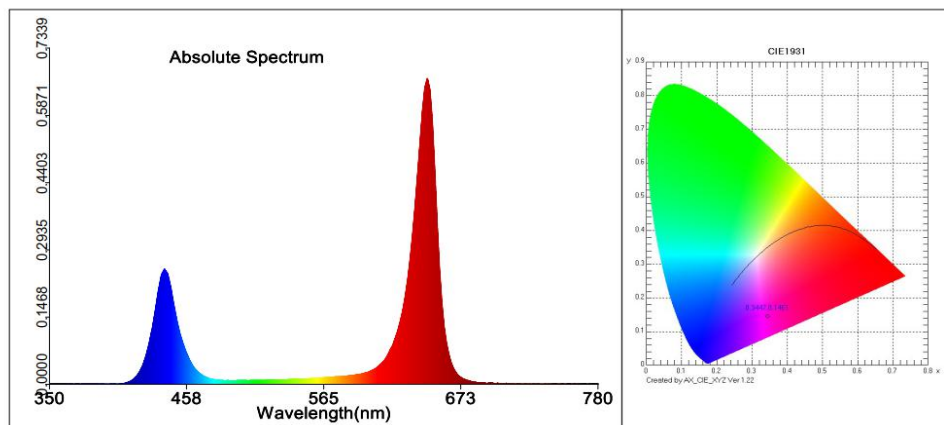

#### Test parameter:

E= 2237.5 lx	E(fc)=207.95 fc		
CIE x= 0.3447	CIE y= 0.1461	CIE u'=0.3393	CIE v'=0.3236
Tc=100000 K	Lp=660.0 nm	HW=20.1 nm	Ld=610.2 nm
Pur=56.3 %	Ratio_R=58.7 %	Ratio_G=32.5 %	Ratio_B=8.8 %
Duv=-0.16639			
Ra=-88.9	R1=-145	R2=-63	R3= 48
R4=-114	R5=-127	R6=-33	R7= 0
R8=-277	R9=-807	R10=-228	R11=-136
R12=-77	R13=-140	R14= 50	R15=-285
SDCM=101.4(F5000)			
White Class:OUT			
E1(400-700nm)=26.803 W/m <sup>2</sup>	E2(380-780nm)=26.921 W/m <sup>2</sup>		
Ech-A=11.438 W/m <sup>2</sup>	Ech-B=7.3405 W/m <sup>2</sup>	Ef=0.099203 W/m <sup>2</sup>	Er=18.416 W/m <sup>2</sup>
Eb=7.0853 W/m <sup>2</sup>	Ey=1.3044 W/m <sup>2</sup>		
Ep=23.666 Wphyto/m <sup>2</sup>	Erb_Ratio=2.5992		
PPFDf=5.9946E-001 μmol/(m <sup>2</sup> ·s)			
PPFD=133.29 μmol/(m <sup>2</sup> ·s)			

## V. Product Main Material

### d) LED Driver

Wide voltage design, AC100V - 277V, 50/60Hz, meets all countries input voltage requirement

Isolating power supply design, ensures safety in usage

### e) LEDs

Using Epileds chips, self-encapsulated LEDs

### f) Heat Dissipation

Adopting high heat conductive materials: AL6063

### g) Water-proof

Waterproof seal grade: IP66

## IV. Product Size & Package

### a) Product size illustration

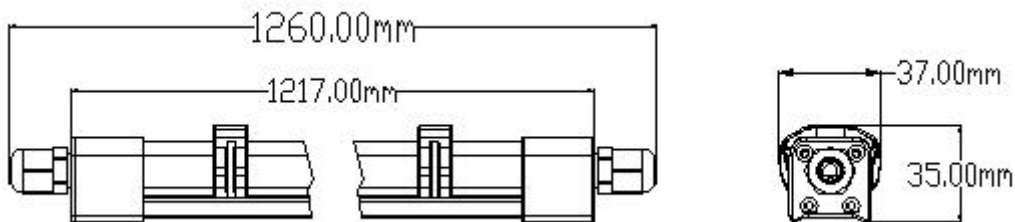

Product packing info

Product P/N	Product NW.	Carton Spec		
		Size	GW.	Qty/ Carton
KES-GL-002	860g	133*27.5*18.5cm	15kg	15 pieces

**b) Product packing illustration**

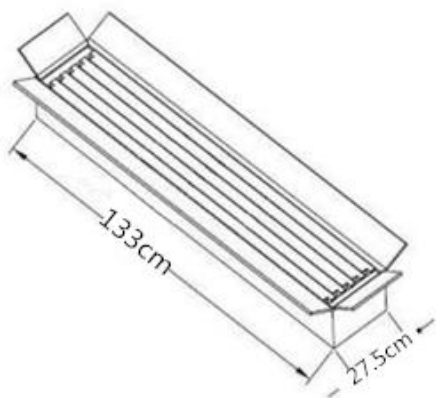

Production carton  
15pcs/carton

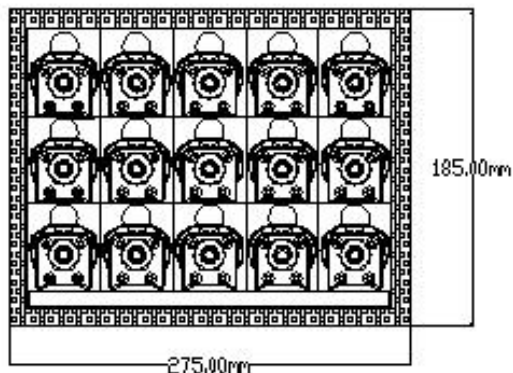

Sectional View

**c) Carton label**

Model: KES-GL-002

Dimension: 133\*27.5\*18.5cm

Quantity: 15 pcs

G.W: 15 KG

Carton No.:            of



**V. Product Installation Illustration**

1. There are two kinds of installation.

**First installation**

1). Fix the lamp holders on the top shelf with tapping screw .



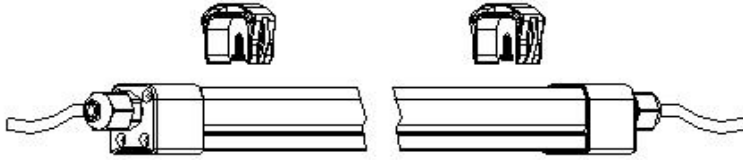

2). Install the lamp into the lamp holders, then plug in the power plug.

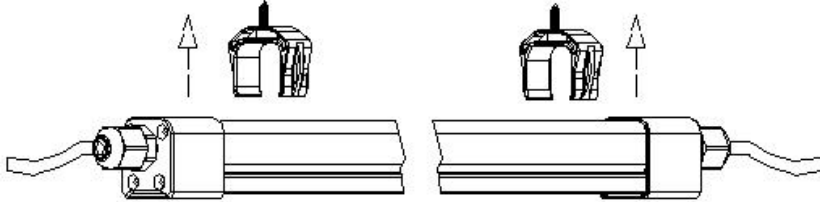

### Second installation

1). Fix the customized screw with pliers on the lamp holders

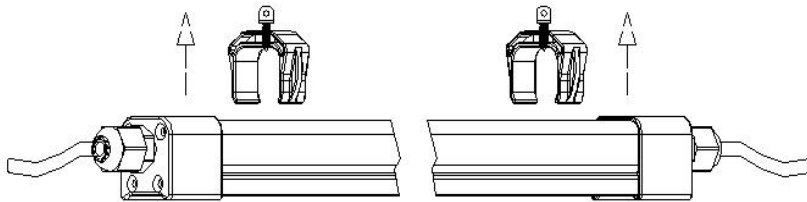

2). Connection the customized screw with hook, connection the other end of hook on the top shelf, then install the lamp into the holder, plug in the power plug.

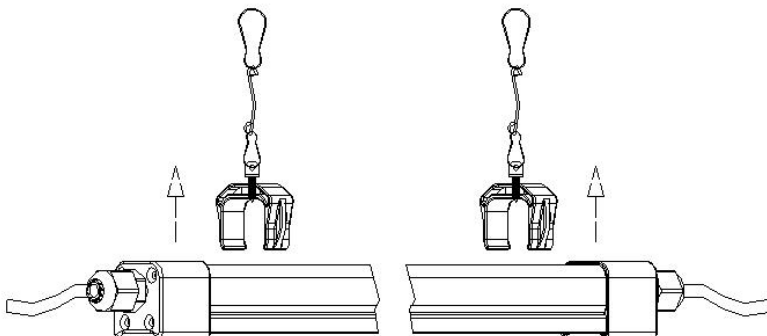

2. There is a connector at the end of LED Grow Light, two lamps can link together.

In the case of 110V, 15 pieces lamp can link together,

In the case of 220V, 20 pieces lamp can link together.

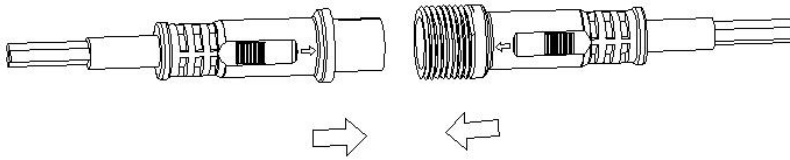

3. There is a cap can be used to plug up the last linked lamp's female to prevent accidents.

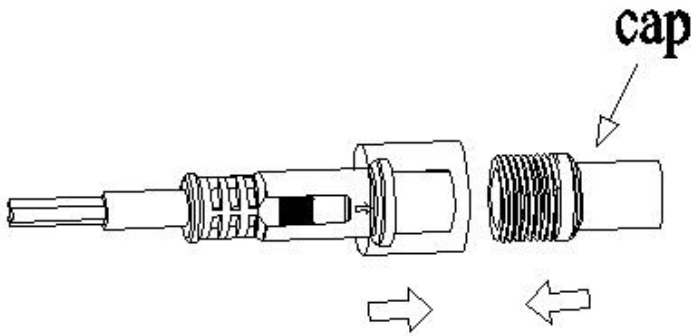

## VI. QA & Safety Standard

### a) Quality control per ISO9001 -2008 Standard

#### Product quality control

- . Finish product QC inspection standard: MIL-STD-105E C=0
- . Production processing QC standard: GB 2829—87 - Periodical checking and sampling procedures
- . QC confirm every production step and keep record

#### Raw material & Components quality control

- . Driver: Per MIL-STD-105E C=0
- . LEDs : Per MIL-STD-105E C=0
- . Heat dissipation: Per MIL-STD-105E C=0

### b) Quality Controlling Items

➤ Switching Test: Switch on/off for 30 times per second within 30 minutes.

➤ Reliability Tests:

	Conditions
High Temperature Operation Test	Ta=50°C, 240hrs
Low Temperature Operation Test	Ta=-20°C, 240hrs
High Temperature Storage Test	Ta=70°C, 240hrs
Low Temperature Storage Test	Ta=-30°C, 240hrs
High Temperature and High Humidity Test	Ta=40°C, 95%RH, 240hrs

➤ Aging Test: Default two days or Per customer requirement

Voltage	Testing Condition	Duration Time
110V	Room Temperature	48 H
220V	Room Temperature	48 H

➤ Safety Test: Leakage current test, Grounding test

➤ PPF D Test

### c) Product Safety Certificates

CE, RoHS, FCC

### d) Product Warranty Statement

LED light life span is usually about 50,000 hours, Base on following terms, Keisue warrants Keisue LED lamps to be free from defects in material and workmanship and to operate from the date of manufacture for the time period of 3 years.

#### Terms and Conditions:

This warranty will not apply in the event of conditions demonstrating abnormal use or stress, such as operating temperatures in excess of maximum rated temperatures, under/over voltage conditions, excessive switching cycles or operating hours, dirty or broken sockets, or improper lamp installation. Replacement of LED driver board provided by Keisue with any other product will void entire warranty.

The user shall promptly return the product at the user's expense to Keisue after receiving instructions as if, when and where to ship product. Failure to follow this procedure shall void this warranty.

## VII. Product Usage Attention Items

- . Please cut off the power before installation and maintenance.
- . LED product is much more durable for collision, knocking, but do not do it for longer life
- . Plug in and the light is on working, do not intentionally connect the light to other electronic components, such as, ballast, transformer, etc.
- . Indoor use, forbid to expose to the out-door or get wet.